

Reduction of Coliforms presents in domestic residual waters by Air-Ozone Micro-Nanobubbles In Carhuaz city, Peru.

Rudy Cruz^a, Jhonny Valverde Flores^{a,b,*},

^a*Department of Environmental engineering, University Cesar Vallejo – Lima Norte, C.P. 15314, Lima 39, Peru.*

^b*Institute of Nanotechnology, Centre of Research and Training to the Regional Development, (CINCADER) Lima, Peru.*

jhoval1@yahoo.es.

Resumen

Perú genera aproximadamente 2 217 946 m³ por día de aguas residuales descargadas al sistema de alcantarillado y sólo el 32% recibe tratamiento. El resto de las aguas se vierten a los ríos, que tienen presencia de coliformes fecales. Se realizaron análisis preliminares de las aguas residuales domésticas del distrito de Carhuaz, con coliformes totales (a 35°C) de 240.000 UNT / 100 mL y coliformes termotolerantes (a 44.5°C) de 130 000 UNT / 100mL a pH 7.17 superando los valores ambientales. Los tratamientos se llevaron a cabo con el generador de micro-nanoburbujas de aire-ozono con un caudal de agua de 4,67 L/min y una presión de la mezcla aire-ozono de 90 PSI, logrando una reducción de coliformes totales de hasta 100 UNT/100 mL (99,96%) y coliformes fecales hasta 100 UNT/100mL (99,92%).

Palabras clave: Aguas residuales domésticas, Micro-Nanoburbujas, ozono, aire, coliformes fecales y totales.

Abstract

Peru generates approximately 2 217 946 m³ per day of wastewater discharged to the sewage system and only 32% receive treatment. The rest of the waters are discharged to the rivers, which have presence of fecal coliforms. Preliminary analyzes of the domestic wastewater of the Carhuaz district were carried out, with total coliforms (at 35°C) of 240,000 CFU / 100 mL and thermotolerant coliforms (at 44.5°C) of 130,000 CFU / 100mL at pH 7, 17 exceeding the environmental standard values. The treatments were carried out with the air-ozone micro-nanobubbles generator with a water flow rate of 4.67 L/min and a pressure of the air-ozone mixture of 90 PSI, achieving a reduction of total coliforms up to 100 CFU/100 mL (99.96%) and fecal coliforms up to 100 CFU/100mL (99.92%).

Key words: Domestic sewage, micro-nanobubbles, ozone, air, fecal and total coliforms.

Introduction

Peru generates approximately 2 217 946 m³ per day of wastewater discharged to the sewage system and will generate 4 842 579 m³ per day of wastewater to 2024. Only 32% receive treatment of the whole sewage system. One person generate 145 L/inhab/day in the Coast, 144 L/inhab/day, in the highlands (Andes), and 136 L/inhab/day in the jungle of wastewater (OEFA, 2014). A novel technology based in micro and nanoscales can solve social, economic and environmental problems.

Nanotechnology is a science focused to nanoscale measures. The environmental nanotechnology is a technological discipline which study properties of natural and man-made nanomaterials, applications, techniques for their characterization, integration processes and transformation into ecosystems (Valverde, 2016). Microbubbles have the ability to change the normal characteristic of water. Bubbles are filled with gas with an internal equilibrium pressure that is less than atmospheric pressure (Tsuge, 2014). The Microbubbles

(MBs) have diameter more than 100 μm , the micro-nanobubbles (MNBs) have diameter between 1 to 100 μm and the nanobubbles (NBs) have diameter less than 1 μm within the fluid field (Valverde, 2016).

A microbubble has unique characteristics, such as high gas dissolution, low rising velocity, and a high interfacial area (Liu et al, 2013). Also, Microbubbles (MBs) possess special properties such as the capacity for generating free radicals (Sadatomi et al., 2007), self-pressurization, and carrying a negative charge. Such properties have attracted much attention in the fields of food science and agriculture (Sumikura and others 2007; Takahashi and others 2007b). MNBs have now attracted attention for applications in engineering areas such as the sewage treatment of wastewater by air flotation (Choung et al 1993, Fan et al. 2010) detergent-free cleaning of adsorbed proteins (Wu et al. 2008, Liu et al. 2008). Studies have shown that it is possible to produce NBs that have a stability lasting from several minutes to days, and even months in aqueous solutions (Wu et al. 2012; Young. 1997).

Ozone (O_3) is a strong oxidizing agent commonly used for sterilization, virus inactivation, deodorization, bleaching (decoloration), and decomposition of organic matter (Takahashi and others 2007a). The physical properties of ozone, including odor, color, and solubility, are the bases for its wide applications in water and wastewater treatment. Ozone is an unstable and colorless gas with pungent fishy smell under ambient pressure and temperature (Khadre et al. 2001). On the other hand, ozone is a chemical reactive reagent exhibiting electrophilic and nucleophilic characteristics, which are closely related to its resonance structures. A large variety of micro-organisms could be effectively inactivated by ozone through cell lysis and nucleic acids destruction (von Gunten 2003a, Kingsbury and Singer 2013, Tachikawa and Yamanaka 2014).

Microorganisms are widely distributed in nature, their diversity and amount is used as an indicator for the sustainable water. The most commonly measured bacterial indicators are: Total coliform (TC), and fecal coliform (FC). Kobayashi et al. (2009) have investigated the ability of CO_2 microbubbles to inactivate *Escherichia coli* (thermotolerant coliform) suspended in a saline solution at a pressure lower than 2 MPa and 313 K. A significant reduction in the bacterial population occurred with microbubble-aided CO_2 treatment.

Besides water potability, the micro-bubble generation technology in water is applied in the following situations:

- Aqua-life culture: fish and oyster farming (Englehardt, 1994).
- Industrial cleaning: in processing of industrial effluents (Ikeura et al., 2011) and sterilization (Nakashima et al., 2012).
- Agriculture: removal of residual food pesticides (Serizawa, 2003).
- In medicine: drug delivery to human organs, diagnosis using ultrasonic cavitation.
- In Health: cardiovascular problems (Valverde, 2016).
- Pollution control: prevent growth of blue-green algae in water bodies (Nakashima et al., 2012) absorption of CO_2 gas (Rijk et al.).
- Separation process: treatment of oil/water emulsion (Takahashi et al., 2007); gas liquid contactors and algal separation (Chu et al., 2008).

Material and methods

It is an applied research and does corresponds to the pre-experimental design. The study's population is domestic wastewater from Carhuaz city, Ancash. Peru; which it is deposited in the Santa river. The experimental process was taken in laboratory.

This research had the following procedure: i) Collection and analysis of the domestic wastewater sample, ii) Treatment of domestic wastewater by applying air-ozone micro-nanobubbles, iii) Final analysis of the treated sample in laboratory, iv) Treatment efficiency.

i) Collection and analysis of domestic wastewater sample

The domestic wastewater samples of the district of Carhuaz-Ancash were collected, following the indications of the Quality Monitoring National Protocol of Water. Physical parameters (as Temperature, Turbidity and electrical conductivity), chemical parameters (as pH and Total Suspended Solids), Biological parameters (as Biological Oxygen Demand, chemical oxygen demand and dissolved oxygen) and bacteriological parameters (as fecal- and total coliforms) were measured by an accredited laboratory for testing in the country.

ii) Treatment of domestic wastewater by applying the air-ozone micro-nanobubbles

The research was carried out ex-situ, in the laboratory, where the whole system was first assembled to generate and to use the air-ozone micro-nanobubbles in domestic wastewater. The MNBs were generated by the device to the MNBs generation. This device was patented by Dr. Eng. Jhonny Valverde Flores. The schematic diagram of experimental apparatus for preparation of MNBs solutions is shown in Figure 1.

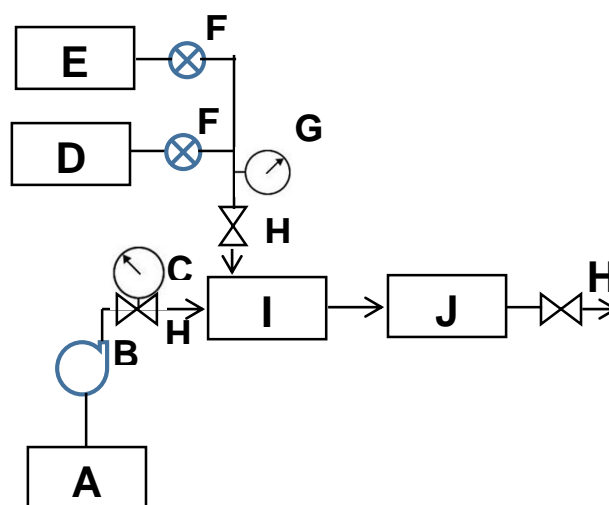

Figure 1. Schematic diagram for the wastewater treatment. Where, A: water tank, B: pump, C: flowmeter, D: air generator, E: ozone generator, F: pressure valve, G: pressure manometer, H: valve (general), I: MNBs generator, J: effluent and water with MNBs.

Three different treatments were dosed in order to evaluate the best reduction of fecal coliforms and total coliforms into the domestic wastewater sample. Treatment 1 is called T1 [750 mL (effluent)/250 mL (MNBs+water)], Treatment 2 is called T2 [500 mL (effluent)/500 mL (MNBs+water)], and treatment 3 is called T3 [250 mL (effluent)/750 mL (MNBs+water)].

iii) Final analysis of the treated sample in laboratory

Results of the three treatments in different concentrations as: physical, chemical, biological and microbiological parameters were analyzed after of using air-ozone micro-nanobubbles.

iv) Treatment efficiency

To measure the MNBs treatment's efficiency on Fecal coliforms (FC) was used the following equation:

$$\% \text{ Remotion}(FC) = \frac{[Fecal\ coliforms]_{initial} - [Fecal\ coliforms]_{end}}{[Fecal\ coliforms]_{initial}} * 100 \quad (1)$$

To measure the MNBs treatment's effectiveness on Total coliforms (TC) was used the following equation:

$$\% \text{ Remotion}(TC) = \frac{[Total\ coliforms]_{initial} - [Total\ coliforms]_{end}}{[Total\ coliforms]_{initial}} * 100 \quad (2)$$

Results and Discussion

- Collection and analysis of domestic wastewater sample

12 liters of domestic wastewater were taken in 1-liter polypropylene bottles for the physical parameters, and sterilized glass containers for the microbiological parameters. The sample temperature was at 15.8 ° C in the field, and was stored in a cooler to preserve the samples at 4 ° C temperature.



Figure 1. Person collects the domestic waste water

- Treatment of domestic wastewater by applying the air-ozone micro-nanobubbles

The necessary materials and equipment to generate air-ozone MNBs were conditioned in the laboratory. Then MNBs were generated with the MNBs generator. A drop was isolated to count with an optic microscope the amount of MNBs. A drop of water (0.050 mL) contains approximately 36 MNBs of air-ozone. The obtained average diameter of a MNB was 7 µm, the water flow was 4.67 L/s, the gas pressure was 90 PSI (Air: 80 % and Ozone: 20 %).

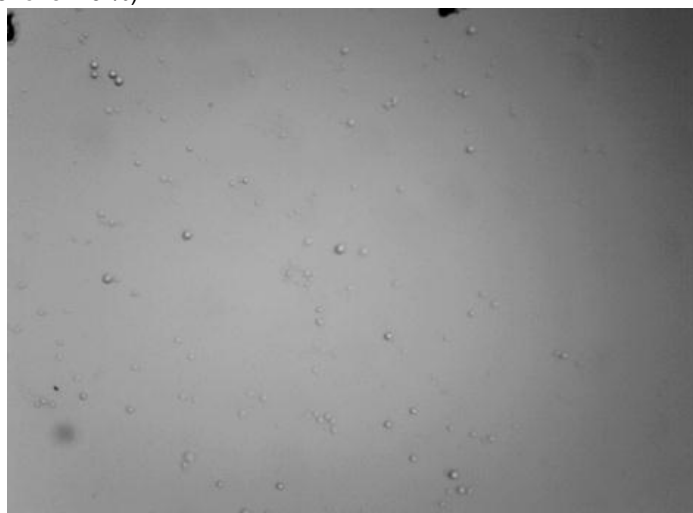

Figure 2. Average diameter of a MNB size is 7 µm

The behavior of MNBs into the domestic wastewater was different in each treatment. The air-ozone MNBs action in T1 is less than T2 and T3. See Figure 3.

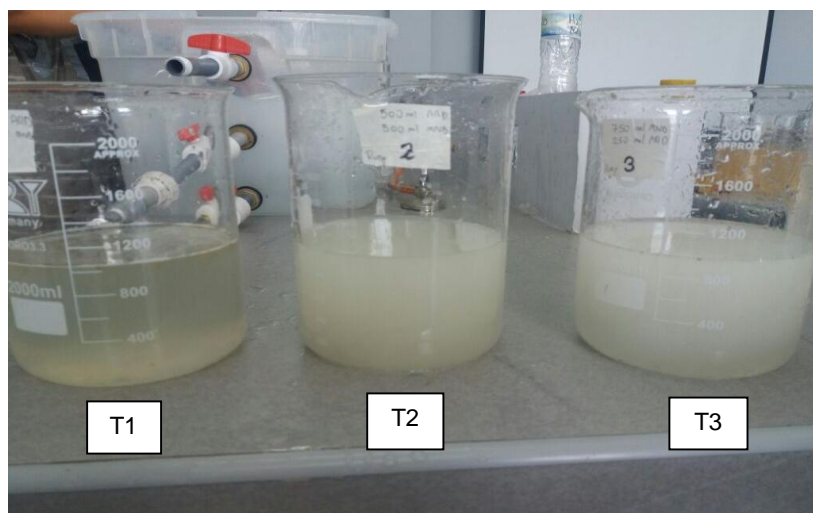

Figure 3. Three different treatments of the domestic wastewater.

Final analysis of the sample treated in laboratory

The water quality parameters were measured to get the final results of the T1, T2 and T3.

Table 1. Physical Parameters

Parameters	Units	Initial Sample	T1 [750 mL (effluent)/250 mL (MNBs+water)]	T2 [500 mL (effluent)/500 mL (MNBs+water)]	T3 [250 mL (effluent)/750 mL (MNBs+water)]
Temperature	°C	15	24.9	25.3	25.7
Turbidity	NTU	128	55.6	44.6	29
Electrical Conductivity	µS/cm	288	603	761	872

The physical parameters measured were: temperature, Turbidity, and electrical conductivity. The temperature in T3 (25.7 °C) was higher than temperatures of T1 (24.9 °C) and T2 (25.3 °C). The temperature changed because in the Andes the temperature is lower than in the Coast. The turbidity in T3 (29 NTU) was lower than the initial turbidity (128 NTU). The electrical conductivity in T3 was higher (872 µS/cm) than the initial electrical conductivity in (288 µS/cm). See Table 1.

Table 2. Chemical Parameters

Parameters	Units	Initial Sample	T1 [750 mL (effluent)/250 mL (MNBS+water)]	T2 [500 mL (effluent)/500 mL (MNBS+water)]	T3 [250 mL (effluent)/750 mL (MNBS+water)]
pH	-	7.17	6.8	7.32	7.62
Total Suspended Solids (TSS)	mg/L	246	89	51	46

The chemical parameters measured were: pH, and Total Suspended Solids (TSS). The pH in T3 (7.62) was higher than the initial pH (7.17). The Total Suspended Solids (TSS) in T3 (46 mg/L) was lower than the initial Total Suspended Solids (246 mg/L). See Table 2.

Table 3. Biological Parameters

Parameters	Units	Initial Sample	T1 [750 mL (effluent)/250 mL (MNBS+water)]	T2 [500 mL (effluent)/500 mL (MNBS+water)]	T3 [250 mL (effluent)/750 mL (MNBS+water)]
Biological Demand (BOD)	Oxygen mg/L	342	20	15	10
Chemical Demand (COD)	Oxygen mg/L	704	200	100	35
Dissolved Oxygen (DO)	mg/L	3.66	5.33	7.21	7.73

The Biological parameters measured were: Biological Oxygen Demand (BOD), Chemical Oxygen Demand (COD), and Dissolved Oxygen (DO). The Biological Oxygen Demand (BOD) in T3 (10 mg/L) was lower than the initial Biological Oxygen Demand (342 mg/L). The Chemical Oxygen Demand (COD) in T3 (35 mg/L) was lower than the initial Chemical Oxygen Demand (704 mg/L). The Dissolved Oxygen (DO) in T3 (7.73 mg/L) was higher than the initial Dissolved Oxygen (DO). in (3.66 mg/L). See Table 3.

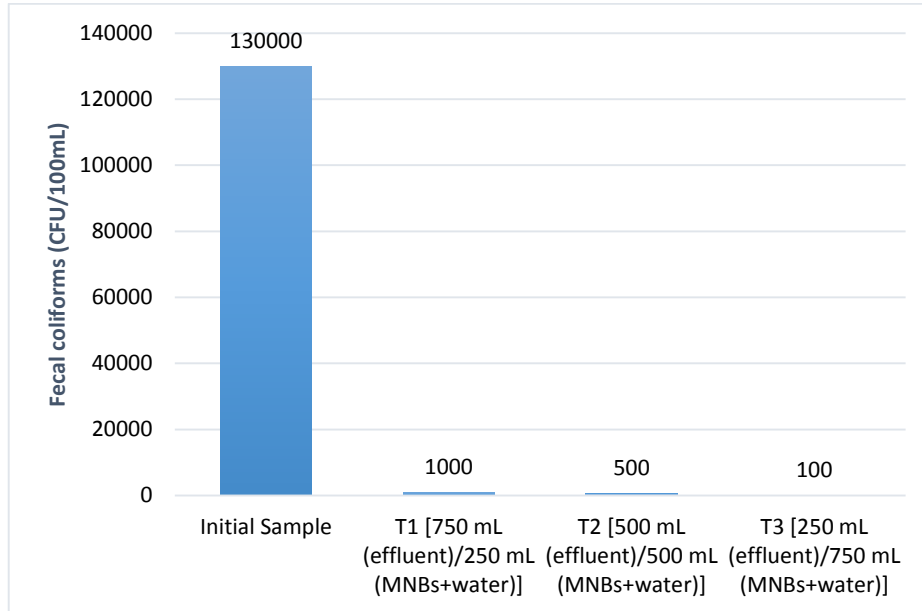

Figure 4. Comparison of three different treatments vs. initial sample of Fecal coliforms

The Bacteriological parameters measured were: Fecal Coliforms and Total Coliforms. The Fecal Coliforms in T3 (100 CFU/100mL) was lower than the initial Fecal Coliforms (130000 CFU/100mL). The T1 reached up to 1000 CFU/100 mL and T2 reached up to 500 CFU/100 mL. See Figure 4.

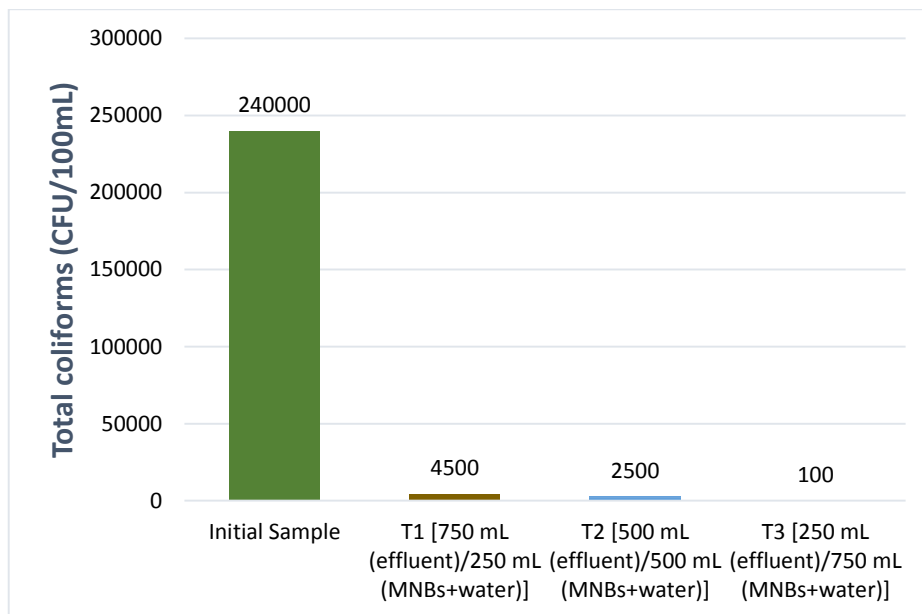

Figure 4. Comparison of three different treatments vs. initial sample of Total coliforms

Total Coliforms in T3 (100 CFU/100mL) was lower than the initial Total Coliforms (240000 CFU/100mL). The T1 reached up to 4500 CFU/100 mL, and T2 reached up to 2500 CFU/100 mL. See Figure 4.

Treatment Efficiency

As the best reduction was in the T3, the efficiency was calculated only for T3.

The MNBs treatment's efficiency on Fecal coliforms in T3 as % Remotion was the following:

$$\% \text{ Remotion} = \frac{130000 - 100}{130000} * 100 = 99.92 \%$$

The MNBs treatment's efficiency on Total coliforms in T3 as % Remotion was the following:

$$\% \text{ Remotion} = \frac{240000 - 100}{240000} * 100 = 99.96 \%$$

In Table 5, you can see the treatment efficiency resume of T3.

Table 5. Treatment's efficiency

Parameters	Units	Initial Sample	T3 [250 mL (effluent)/750 mL (MNBS+water)]	Efficiency
Fecal coliforms	CFU/100mL	130000	100	99.92%
Total coliforms	CFU/100mL	240000	100	99.96%

The % Remotion of Fecal Coliforms in T3 was 99.92%. The % Remotion of Total Coliforms in T3 was 99.96%.

Conclusion

- There are reductions of fecal and total coliforms presents in domestic wastewater. The initial fecal coliform concentration was 130000 CFU /100 mL and total coliforms 240000 CFU /100 mL, after applying the air-ozone micro-nanobubbles, the coliforms concentration was reduced. The reduction of fecal- and total coliforms in Treatment 1 was 1000 CFU / 100 mL and 4500 CFU / 100 mL, in Treatment 2 the reduction was 500 CFU / 100 mL and 2500 CFU / 100 mL, in Treatment 3 the reduction was 100 CFU / 100 mL and 100 CFU / 100 mL, respectively.
- The three treatments were obtained from different measures. The fecal coliforms in T1, T2 and T3 were within the Water's Environmental Quality Standard (EQS) for category 3 (in vegetables irrigation), which is 1000 CFU/100mL and the total coliforms in T1 and T2 were out of the Water's Environmental Quality Standard (EQS) for category 3, which is 1000 CFU/100mL. However T3 was within the EQS.
- The best treatment reduction Efficiency of fecal- and total coliforms in domestic wastewater was in T3 by applying air-ozone micro-nanobubbles. It was obtained 99.58% for fecal coliforms and 99.01% for total coliforms.

Acknowledgments

We gratefully acknowledge to the Department of Environmental engineering, University Cesar Vallejo – Lima Norte, for giving facilities in environmental issues. We also thank to the Institute of Nanotechnology, Centre of Research and Training to the Regional Development, (In Spanish, Centro de Investigación y Capacitacion

para el Desarrollo Regional-CINCADER) for allowing us to use the equipment to generate micro-nanobubbles and technical experiences.

References

- Choung J, Lutell GH, Yoon RH: Characterization of operating parameters in the cleaning zone of microbubble column flotation. *Int J Mineral Process* 1993, 39:31-40.
- Chu, L.-B., S.-T. Yan, et al. "Enhanced sludge solubilization by microbubble ozonation." *Chemosphere*. 2008. 72: 205-212.
- Englehardt, J. "Identifying Promising Hazardous Waste Reduction Technologies", *Journal of Environmental Engineering*, 120, pp. 513-526, 1994
- Fan M, Tao D, Honaker R, Luo Z: Nanobubble generation and its application in froth flotation (part I): nanobubble generation and its effects on properties of microbubble and millimetre scale bubble solutions. *Mining Sci Technol*. 2010. 20:1-19.
- Ikeura, H., F. Kobayashi, et al. "Removal of residual pesticide, fenitrothion, in vegetables by using ozone microbubbles generated by different methods". *Journal of Food Engineering*. 2011. 103: 345-349.
- Khadre MA, Yousef AE, Kim JG. Microbiological aspects of ozone applications in food: a review. *J Food Sci* 2001; 66: 1242–1252.
- Kingsbury RS, Singer PC. Effect of magnetic ion exchange and ozonation on disinfection by-product formation. *Water Res* 2013; 47: 1060–1072.
- Kobayashi F, Ikeura H, Ohsato S, Goto T, Tamaki M. Disinfection using ozone microbubbles to inactivate *Fusarium oxysporum* f. sp. *melonis* and *Pectobacterium carotovorum* subsp. *Carotovorum*. *Crop Protection* 2011; 30: 1514 – 1518.
- Liu, C., Hiroshi, T., Zhang, J., Zhang, L., Yang, J., Huang, X., Kubota, N. Successful Application of Shirasu Porous Glass (SPG) Membrane System for Microbubble Aeration in Biofilm Reactor Treating Synthetic Wastewater. *Separation and Purification Technology*. 2013 Volume 103, pp. 53–59
- Liu G, Wu Z, Craig VSJ: Cleaning of protein-coated surfaces using nanobubbles: an investigation using a quartz crystal microbalance. *J Phys Chem C* 2008, 112:16748-16753.
- Nakashima, T., Kobayashi, Y. and Hirata, Y. 2012. Method to Exterminate Blue-Green Algae in a Large Pond and To Improve Plant Growth by Micro-Nano Bubbles in Activated Water. *Acta Hort. (ISHS)* 2012. 938:391-400
- OEFA. Residual water. 2014. https://www.oefa.gob.pe/?wpfb_dl=7827.
- Rijk, S. E. D., J. H. J. M. V. D. Graaf, et al. "Bubble Size In Flotation Thickening". *Water Research*. 1994. 28(2): 465-473.
- Sadatom, M., A. Kawahara, et al. "An advanced microbubble generator and its application to a newly developed bubble-jet-type air-lift pump." *Multiphase Science and Technology*. 2007. 19(4): 323-342.
- Serizawa, Akimi, et al. "Laminarization of micro-bubble containing milky bubbly flow in a pipe." *Proceedings of 3rd European-Japanese Two-Phase Flow Group Meeting*. 2003.
- Tachikawa M, Yamanaka K. Synergistic disinfection and removal of biofilms by a sequential two-step treatment with ozone followed by hydrogen peroxide. *Water Res* 2014; 64: 94–101.
- Takahashi M, Chiba K, Li P. Free-radical generation from collapsing microbubbles in the absence of a dynamic stimulus. *J Phys Chem*. 2007a. B 111:1343–7.
- Takahashi M, Chiba K, Li P. Formation of hydroxyl radicals by collapsing ozone microbubbles under strongly acidic conditions. *J Phys Chem*. 2007b. B 111:11443–6.
- Valverde, J. Nanotechnology for the Environmental Engineering. In: *First International Congress in environmental Engineering oriented to environmental technologies: 6th to 11th october*. Lima, 2016, pp. 26.
- Von Gunten U. Ozonation of drinking water: part II. Disinfection and by-product formation in presence of bromide, iodide or chlorine. *Water Res* 2003a; 37: 1469–1487.
- Wu Z, Chen H, Dong Y, Mao H, Sun J, Chen S, Craig VSJ, Hu J: Cleaning using nanobubbles: defouling by electrochemical generation of bubbles. *J Colloid Interface Sci* 2008, 328:10-14.
- Wu C, Nessel N, Masliyah J, Xu Z. Generation and characterization of submicron size bubbles. *Adv. Colloid Interfac*. 2012;179-182:123-132.
- Yount, DE. On the elastic properties of the interfaces that stabilize gas cavitation nuclei. *J. Colloid Interf. Sci*. 1997;193:50-59.